

Transient Voltage Suppressor

Features

- IEC 61000-4-2(ESD)±15KV(air), ±8KV(contact)
- 350Watts peak pulse power (tp=8/20μS)
- Ultra low capacitance:320pF maximum
- Low clamping voltage
- Moisture sensitivity level: Level 1
- Weight 5.0 mg
- Small package:SOD-323

Exterior



SOD-323

Application information

- xDSL secondary
- USB power

Agency Approvals

Icon	Description
RoHS	Compliance with 2011/65/EU
HF	Compliance with IEC61249-2-21:2003
	Mean lead free

Part Number and Electrical Parameter

Part Number	I _{DRM} @V _{DRM}		V _{BR} ^① @I _R		V _c @I _{pp} ^②		V _c @I _{pp} ^②		Co ^③
	μA	V	V	mA	V	A	V	A	pF
	MAX		MIN		MAX		MAX		MAX
BV_SD05	5	5	6	1	9.8	1	15	24	320

Absolute maximum ratings measured at T= 25°C RH = 45%-75% (unless otherwise noted).

① V_{BR} is measured at I_R=1mA

② Surge Waveform: 8/20 μ S.

③ Off-state capacitance is measured in V_{DC}=0V, V_{RMS}=1V, f=1MHz

Part Numbering System

BV SD05
(1) (2)

(1) Bencent Transient Voltage Suppressor
(2) Series: 05 etc.

Mark

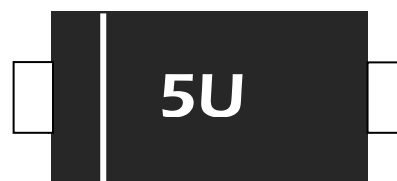

5U: Part Number

Transient Voltage Suppressor

Version: A0 2014-04-29

V-I Curve

Parameters	Definition
V_C	Clamping Voltage
I_{PP}	Surge Waveform 8/20 μ s
V_{DRM}	Stand-off Voltage
V_{BR}	Breakdown Voltage
I_{DRM}	Reverse Leakage Current
I_R	Test Current
P_{pp}	Peak Pulse Power Dissipation

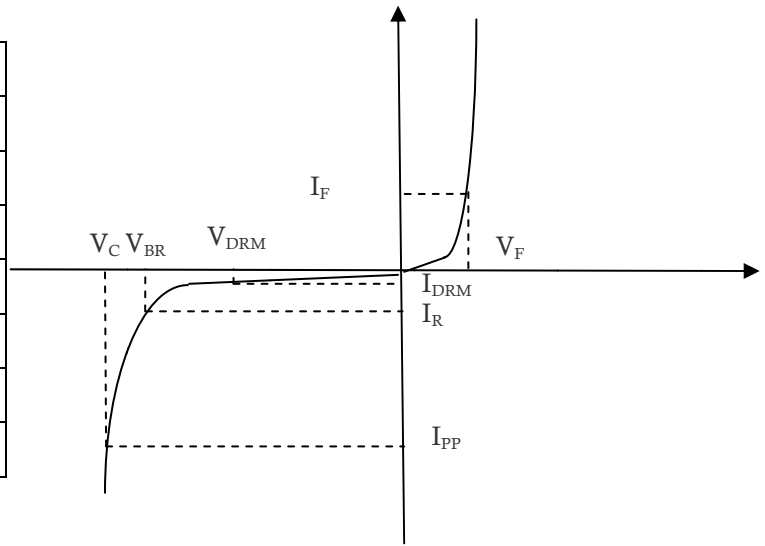

Typical Characteristics

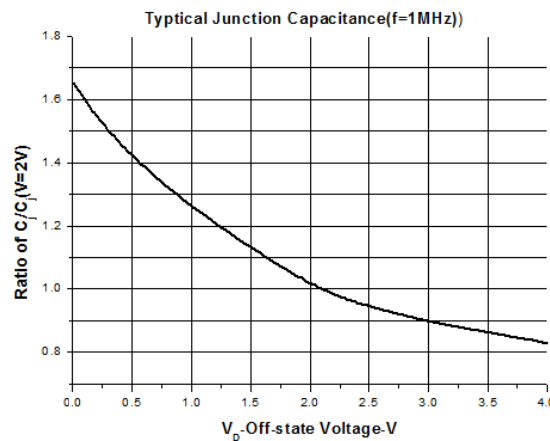
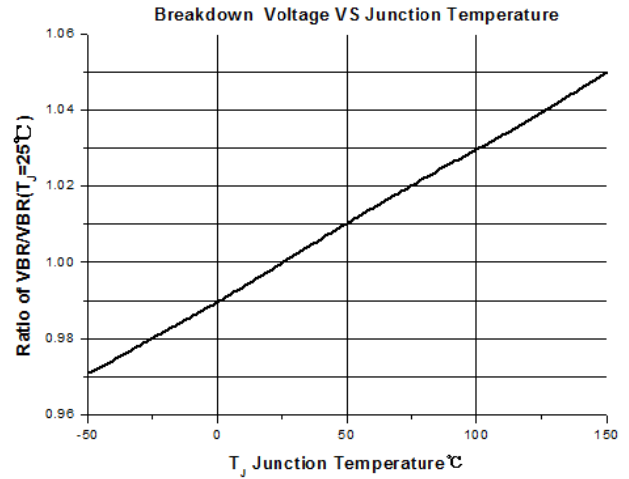
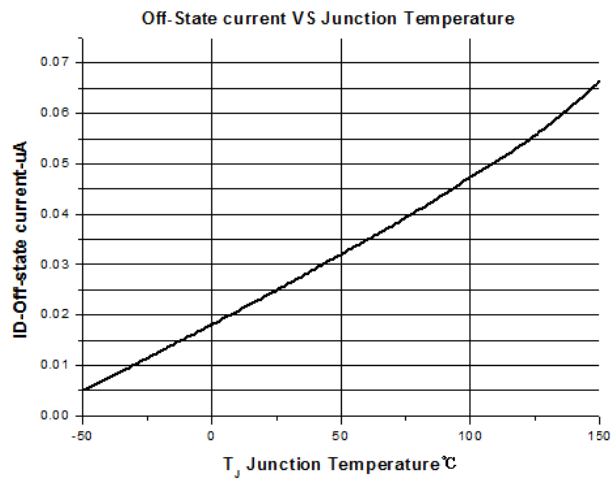

Thermal Considerations

symbol	Parameter	Value	Unit
T_J	Operating Junction Temperature Range	-55 to +150	$^{\circ}$ C
T_S	Storage Temperature Range	-55 to +150	$^{\circ}$ C

Transient Voltage Suppressor

Version: A0 2014-04-29

Environmental Characteristics

Testing items	Technical standards
High Temperature Reverse Bias Test	Temperature: $150\pm 3^{\circ}\text{C}$ Bias= $80\%V_{\text{DRM}}$ Time:168H
High Temperature Life Test	Temperature: 150°C Time:168H
High-low Temperature Cycle Test	Temperature: From -40°C to 125°C Dwell time : 30min,10cycles
High Temperature &High Humidity Test	Temperature: 85°C Humidity:85% Time:168H
Pressure Cooker Test	Temperature: 121°C , 2atm. Humidity:100% Time:24H
Resistance of Soldering Heat	Temperature: $260\pm 5^{\circ}\text{C}$ Time of dip soldering: 10s, 3times

Note: The above testing items can be specified by customer's special request

Product Dimensions

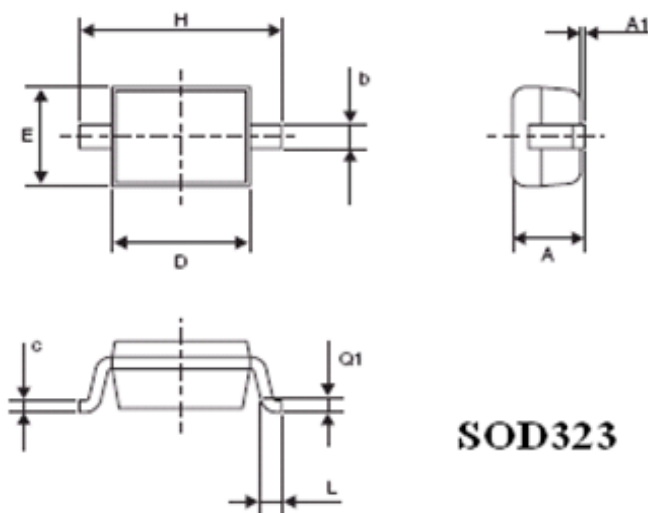

REF	mm	inch
A	1.17	0.046
A1	0.1	0.004
b	0.34 ± 0.10	0.013 ± 0.0039
c	0.17 ± 0.08	0.007 ± 0.0032
D	1.66 ± 0.14	0.065 ± 0.0055
E	1.28 ± 0.17	0.050 ± 0.0066
H	2.5 ± 0.2	0.098 ± 0.0079
L	0.28 ± 0.18	0.011 ± 0.0071
Q1	0.25 ± 0.15	0.010 ± 0.0059

Recommended Soldering Pad

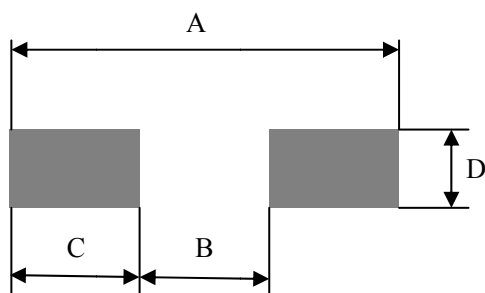

REF	mm	inch
A	3.20	0.126
B	1.08	0.043
C	1.06	0.042
D	0.54	0.021

Transient Voltage Suppressor

Version: A0 2014-04-29

Reflow Profile

Reflow Condition		Pb-Free assembly
Pre Heat	Temperature Min	150°C
	Temperature Max	200°C
	Time (min to max)	60 – 180 secs
Average ramp up rate (Liquidus) T _{amp} (T _L) to peak		3°C/s max
T _s (max) to T _L - Ramp-up Rate		3°C/s max
Reflow	- Temperature (T _L) (Liquidus)	217°C
	- Temperature (T _L)	60 – 150 secs
Peak Temperature (T _P)		260+0/-5 °C
Time within 5°C of actual peak Temperature (T _P)		8– 15secs
Ramp-down Rate		6°C/s max
Time 25°C to peak Temperature (T _P)		8 min max.
Do not exceed		260°C

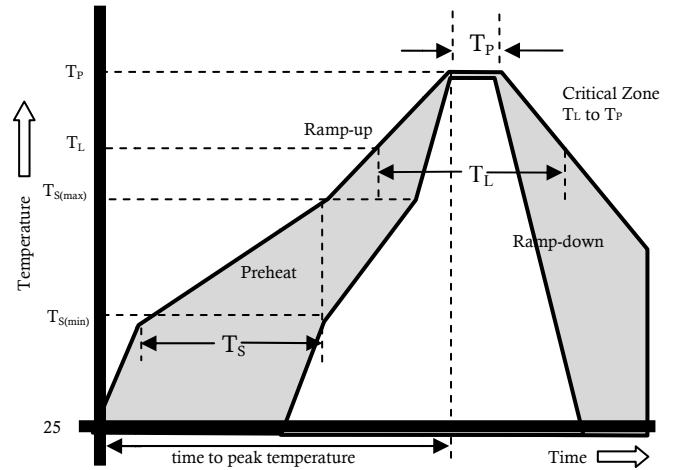

Package Reel Information

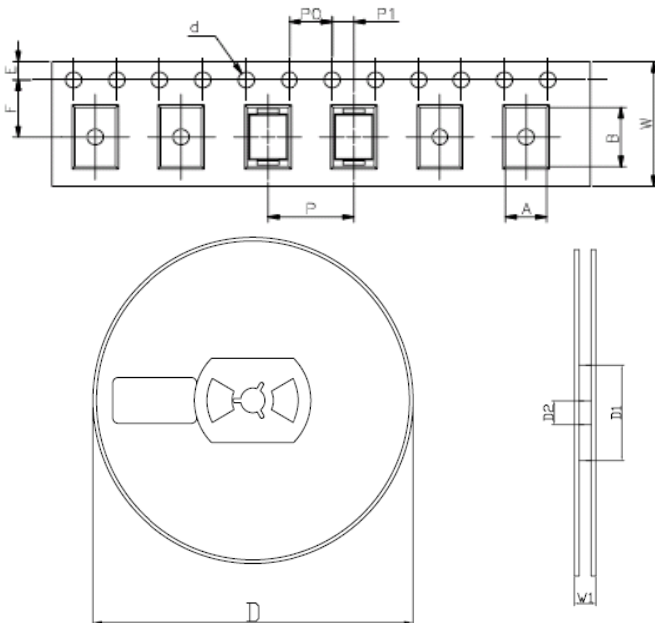

REF	mm	inch
A	1.46+/-0.1	0.057+/-0.004
B	2.9+/-0.1	0.114+/-0.004
d	1.25+/-0.1	0.049+/-0.004
D	178+/-1.0	7.01+/-0.039
D1	55+/-3	2.165+/-0.118
D2	13+/-0.5	0.512+/-0.020
E	1.75+/-0.1	0.069+/-0.004
F	3.5+/-0.2	0.138+/-0.008
P	4.0+/-0.2	0.158+/-0.008
P0	4.0+/-0.2	0.158+/-0.008
P1	2.0+/-0.2	0.079+/-0.008
W	8.0+/-0.2	0.315+/-0.008
W1	14.4+/-0.5	0.567+/-0.020

OUTLINE	REEL (PCS)	PER CARTON (PCS)	CARTON SIZE(mm)		
			L	W	H
TAPING	3,000	90,000	390	370	220