

1200V40A 绝缘栅双极型晶体管

● 特点/Features

- CoolWatt® I 沟槽栅场截止技术/CoolWatt® I Trench-FS technology
- 低饱和压降/Low V_{CEsat}
- 低动态损耗/Low switching losses
- 反并快恢复二极管/With anti-parallel fast recovery diode
- 正温度系数/Positive temperature coefficient
- 高可靠性/High reliability

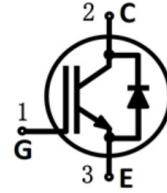

● 应用领域/Applications

- 工业焊机/Industrial welding
- 备用电源/UPS
- 开关电源/SMPS

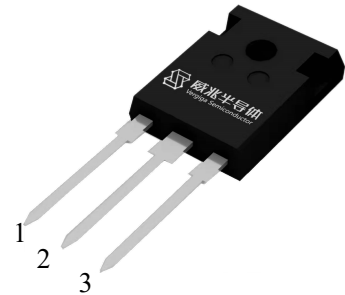

TO-247

型号/Part ID	V_{CE} (V)	I_{CNOM} (A)	$V_{CESAT@25^{\circ}C}$ (V)	封装/Package	丝印/Marking
HCKW40N120H1	1200	40	1.95	TO-247	K40H1201

● 最大额定值/Maximum Rated Values

符号 Symbol	参数 Parameter	条件 Condition	值 Value	单位 Unit
V_{CES}	集电极-发射极电压 Collector-emitter voltage	$T_{vj}=25^{\circ}C$	1200	V
I_C	集电极连续直流电流 DC collector current	$T_C = 25^{\circ}C$ $T_C = 100^{\circ}C$	80 40	A
I_{Cpuls}	集电极可重复脉冲电流 Pulsed collector current	$T_{vj} \leq 150^{\circ}C$	120	A
V_{RRM}	二极管反向峰值电压 Repetitive peak reverse voltage	$T_{vj}=25^{\circ}C$	1200	V
I_F	二极管连续直流电流 Diode continuous forward current	$T_C = 25^{\circ}C$ $T_C = 100^{\circ}C$	40 20	A
I_{Fpuls}	二极管可重复脉冲电流 Diode pulsed current	$T_{vj} \leq 150^{\circ}C$	60	A

V_{GE}	栅极-发射极电压 Gate-emitter voltage	$T_{vj}=25^{\circ}\text{C}$	± 20	V
P_{tot}	总耗散功率 Power dissipation	$T_C = 25^{\circ}\text{C}$	484	W
T_{vj}	可工作结温 Operating junction temperature		-40~+ 175	$^{\circ}\text{C}$
T_{stg}	储存温度 Storage temperature		-50~ + 150	$^{\circ}\text{C}$
M	安装扭矩 Mounting torque	M3	0.6	Nm

● 热特性/Thermal Characteristic

符号 Symbol	参数 Parameter	最大值 Maximum	单位 Unit
$R_{thJC-IGBT}$	IGBT 芯片到底板热阻 IGBT thermal resistance junction-case	0.31	K/W
$R_{thJC-FRD}$	二极管芯片到底板热阻 FRD thermal resistance junction-case	1.2	K/W
R_{thJA}	芯片到环境热阻 Thermal resistance junction-ambient	40	K/W

● 电气特性/Electrical Characteristic

符号 Symbol	参数 Parameter	测试条件 Test conditions	值Value			单位 Unit
			最小 Min.	典型 Typ.	最大 Max.	
$V_{(BR)CES}$	集电极-发射极击穿电压 Collector-emitter breakdown voltage	$V_{GE} = 0V,$ $I_C=0.5mA, T_{vj}=25^{\circ}\text{C}$	1200	—	—	V
$V_{CE(sat)}$	集电极-发射极饱和压降 Collector-emitter saturation voltage	$V_{GE}=15V, I_C=40A, T_{vj}=25^{\circ}\text{C}$	—	1.95	2.20	
$V_{GE(th)}$	门极开启阈值电压 Gate-emitter threshold voltage	$V_{GE}= V_{CE}, I_C=1.5mA, T_{vj}=25^{\circ}\text{C}$	4.8	5.6	6.4	
V_F	二极管正向导通压降 Diode forward voltage	$V_{GE}= 0V, I_F=20A, T_{vj}=25^{\circ}\text{C}$	—	1.65	2.10	
I_{GES}	门极-发射极漏电流 Zero gate voltage collector current	$V_{GE}=20V, V_{CE}=0V$	—	—	200	nA
I_{CES}	集电极-发射极漏电流 Zero gate voltage collector current	$V_{CE} =1200V, V_{GE}=0V, T_{vj}=25^{\circ}\text{C}$ $T_{vj}=150^{\circ}\text{C}$	—	—	0.25 1.00	mA
R_{Gin}	内部门极电阻 Integrated gate resistor	—	—	0	—	Ω
C_{ies}	输入电容 Input capacitance	$V_{GE} = 0V, V_{CE}= 25V,$ $f = 1MHz, T_{vj}=25^{\circ}\text{C}$	—	5120	—	pF
C_{oes}	输出电容 Output capacitance		—	183	—	
C_{res}	反向传输电容 Reverse transfer capacitance		—	125	—	
Q_g	门极电量 Gate charge	$I_C =40A, V_{CE}=960V,$	—	257	—	nC

Q_{ge}	门极-发射极电量 Gate-emitter charge	$V_{GE}=15V, T_{vj}=25^{\circ}C$	—	43	—	
Q_{gc}	门极-集电极电量 Gate-collector charge		—	134	—	
$V_{GE(pl)}$	米勒平台电压 Gate-emitter plateau voltage	$I_c=40A, V_{CE}=960V,$ $V_{GE}=0/15V, T_{vj}=25^{\circ}C$	—	9.1	—	V

● 动态特性/Dynamic Characteristic (With inductive load)

符号 Symbol	参数 Parameter	测试条件 Test conditions	值Value			单位 Unit
			最小 Min.	典型 Typ.	最大 Max.	
IGBT 特性_25°C/IGBT Characteristic_25°C:						
$T_{d(on)}$	开启延迟时间 Turn-on delay time	$V_{CC}=600V, I_c=40A,$ $R_{on}=10\Omega, R_{off}=10\Omega,$ $C_{ge}=0nF, V_{GE}=0V/15V,$ $L_{load}=100uH, T_{vj}=25^{\circ}C$	—	100	—	ns
T_r	上升时间 Rise time		—	90	—	
$T_{d(off)}$	关闭延迟时间 Turn-off delay time		—	316	—	
t_f	下降时间 Fall time		—	44	—	
E_{on}	单次开启损耗 Turn-on energy		—	4.09	—	mJ
E_{off}	单次关闭损耗 Turn-off energy		—	1.55	—	
E_{total}	单脉冲总损耗 Total switch energy		—	5.64	—	
IGBT 特性_150°C/IGBT Characteristic_150°C:						
$T_{d(on)}$	开启延迟时间 Turn-on delay time	$V_{CC}=600V, I_c=40A,$ $R_{on}=10\Omega, R_{off}=10\Omega,$ $C_{ge}=0nF, V_{GE}=0V/15V,$ $L_{load}=100uH, T_{vj}=150^{\circ}C$	—	380	—	ns
T_r	上升时间 Rise time		—	88	—	
$T_{d(off)}$	关闭延迟时间 Turn-off delay time		—	349	—	
t_f	下降时间 Fall time		—	55	—	
E_{on}	单次开启损耗 Turn-on energy		—	5.86	—	mJ
E_{off}	单次关闭损耗 Turn-off energy		—	1.82	—	
E_{total}	单脉冲总损耗 Total switch energy		—	7.68	—	
二极管特性_25°C/Diode Characteristic_25°C:						
E_{rec}	反向恢复损耗 Reverse recovery energy	$I_F=40A, V_R=600V,$ $V_{GE}=0/15V, R_{ON}=10\Omega, T_{vj}=25^{\circ}C$	—	0.969	—	mJ
t_{rr}	二极管反向恢复时间 Diode reverse recovery time		—	227	—	nS
Q_{rr}	二极管反向恢复电量 Diode reverse recovery charge		—	2.97	—	uC
I_{rrm}	反向恢复峰值电流 Diode peak reverse recovery current		—	26.8	—	A
di_{rr}/dt	恢复下降电流最大电流变化率 Recovery current during t_{rr}		—	236	—	A/uS
二极管特性_150°C/Diode Characteristic_150°C:						
E_{rec}	反向恢复损耗 Reverse recovery energy	$I_F=40A, V_R=600V,$ $V_{GE}=0/15V, R_{ON}=10\Omega,$ $T_{vj}=150^{\circ}C$	—	1.89	—	mJ
t_{rr}	二极管反向恢复时间 Diode reverse recovery time		—	364	—	nS

Qrr	二极管反向恢复电量 Diode reverse recovery charge	—	5.74	—	uC
Irrm	反向恢复峰值电流 Diode peak reverse recovery current	—	34.8	—	A
di _{rr} /dt	恢复下降电流最大电流变化率 Diode peak rate of fall of reverse Recovery current during t _r	—	284	—	A/uS

● **特征曲线/ Characteristic Curve**

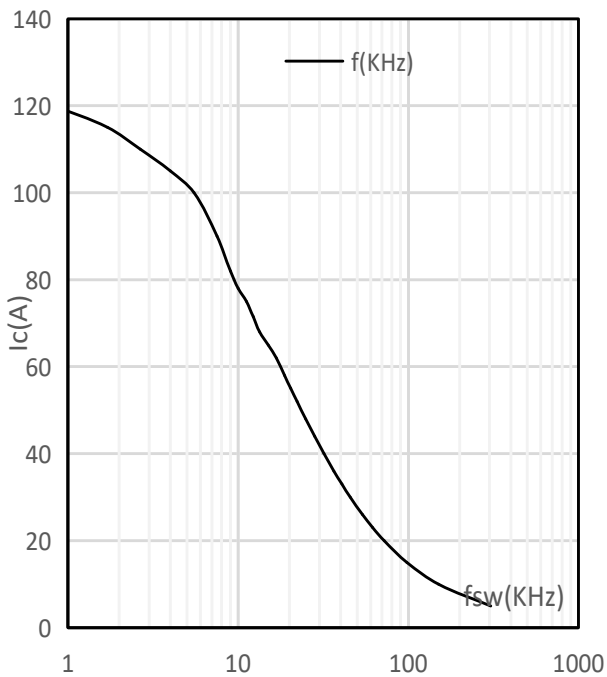

频率-电流特性/Typical fsw as a function of IC

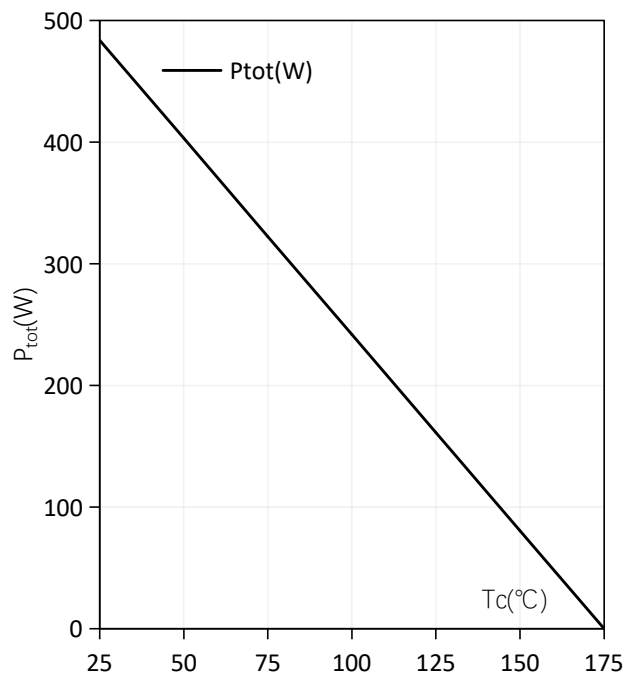

耗散功率-温度特性/P_{tot} as a function of case Temperature

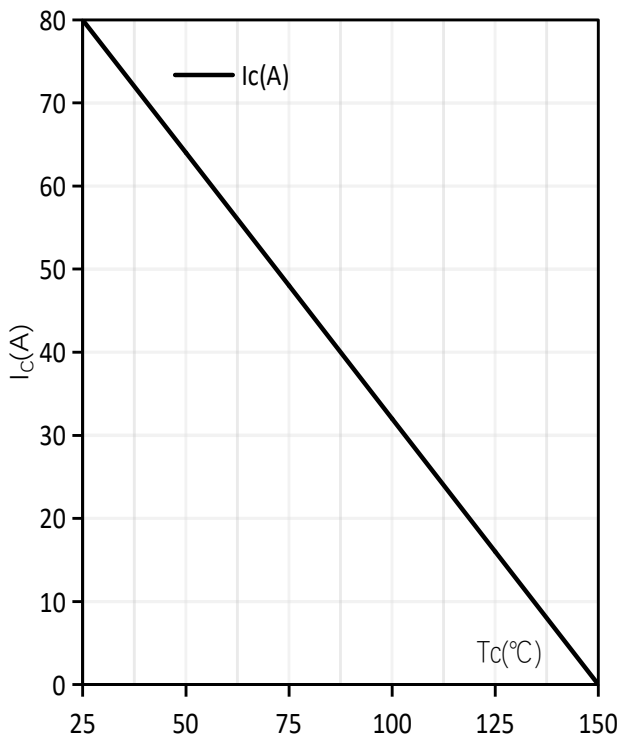

电流-底板温度特性/ I_c as a function of case temperature

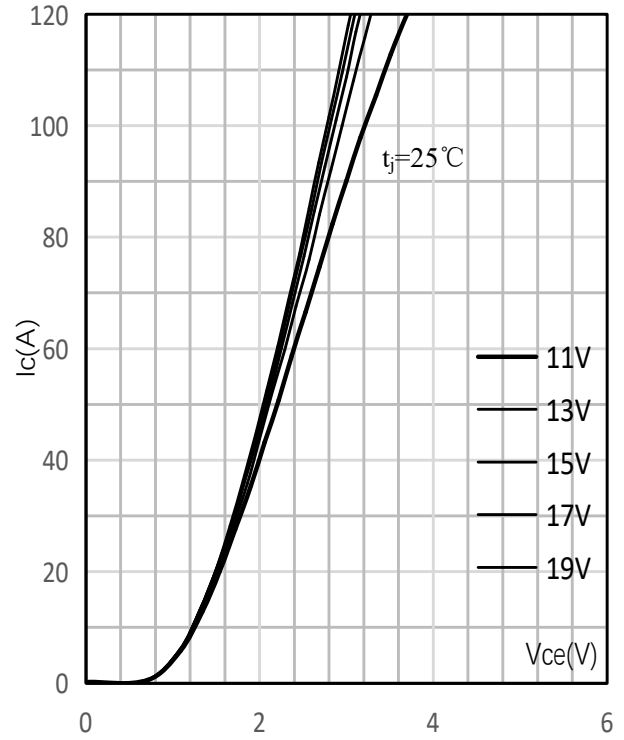

输出特性_25°C/ Typical Output Characteristic_25°C

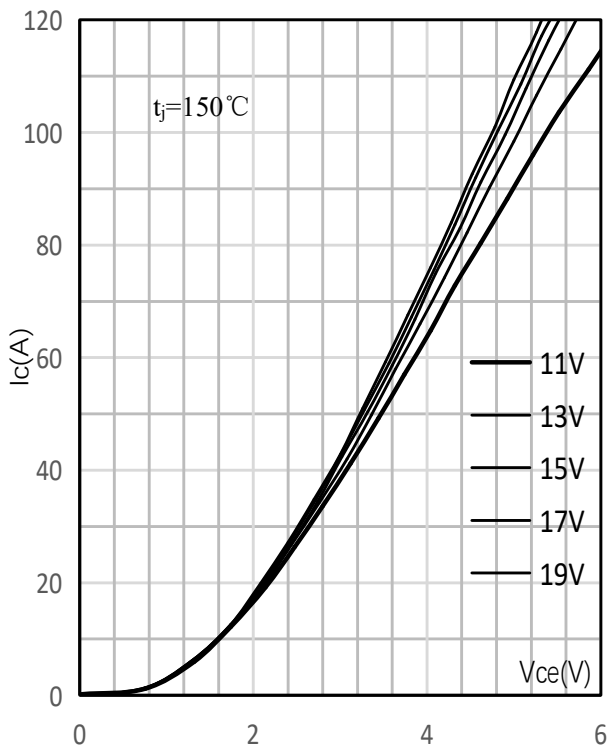

输出特性_150°C/ Typical Output Characteristic_150°C

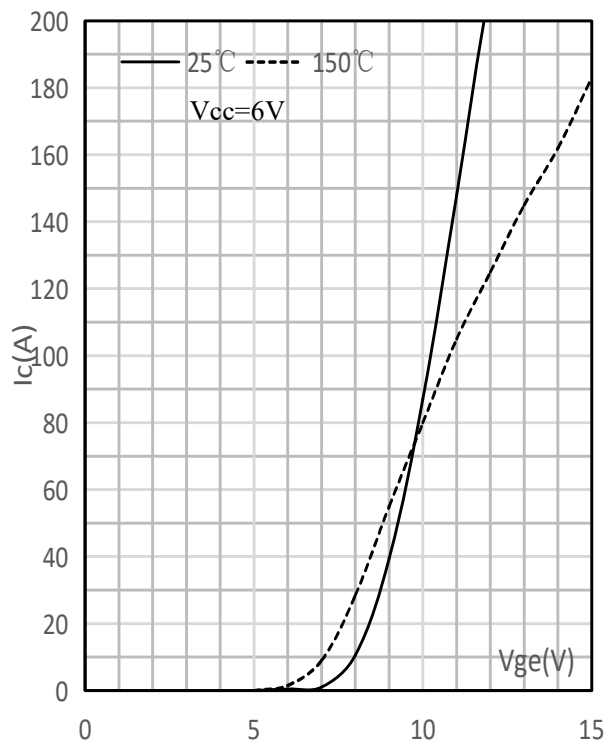

输出特性/ Typical Output Characteristic

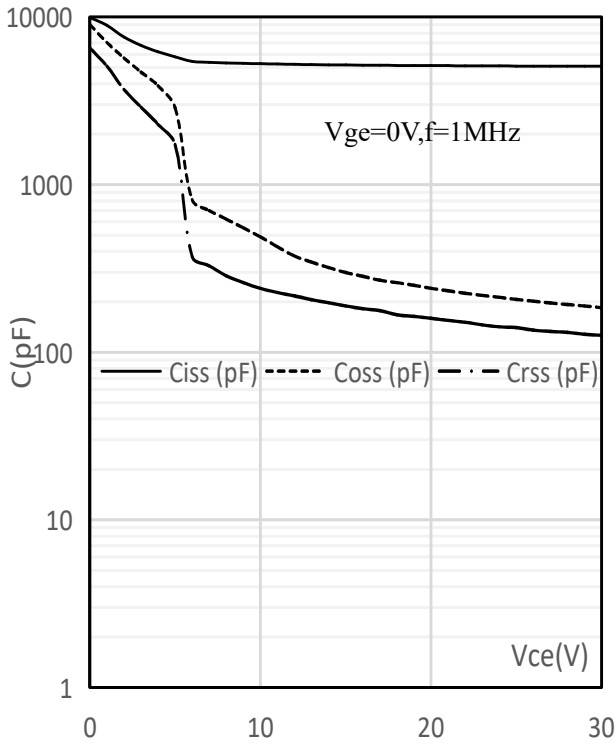

寄生电容/Capacitance as a function of Vce

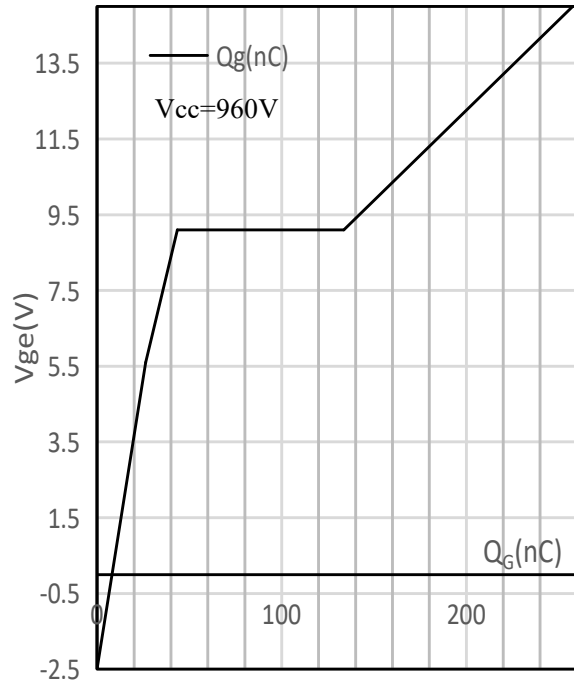

门极电量/Typical gate charge

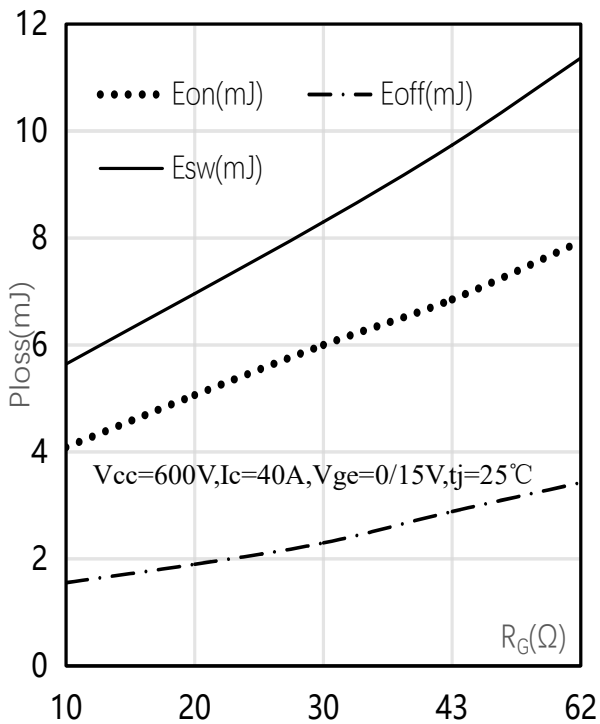

动态损耗-门极电阻特性/Typical switching losses of R_G

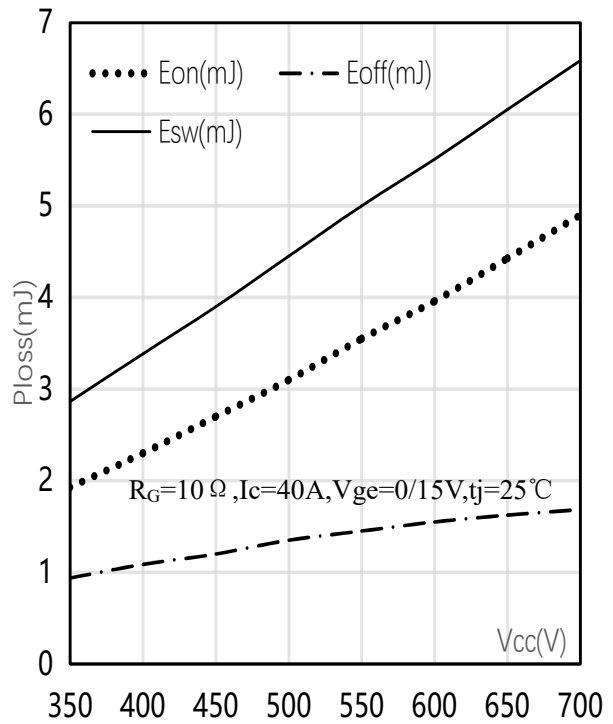

动态损耗-电压特性/Typical switching losses of V_{CC}

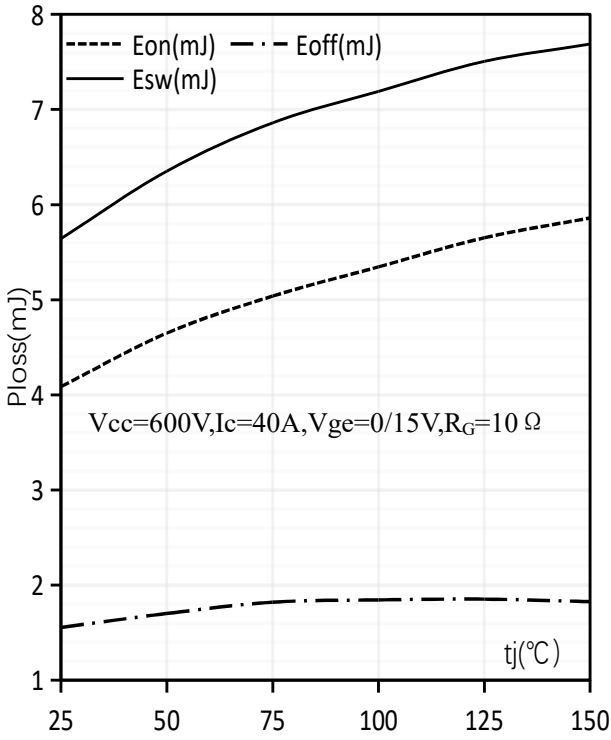

动态损耗-温度特性/Typical switching losses of t_j

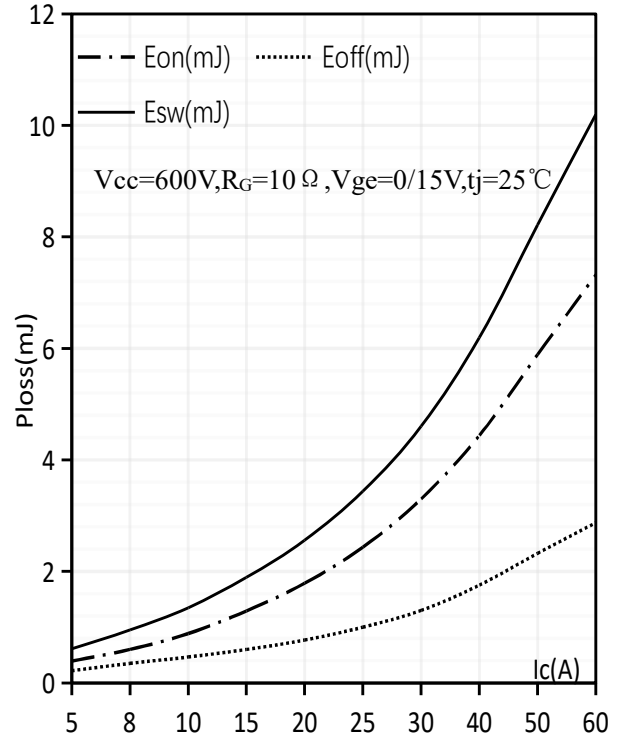

动态损耗-电流特性/Typical switching losses of I_c

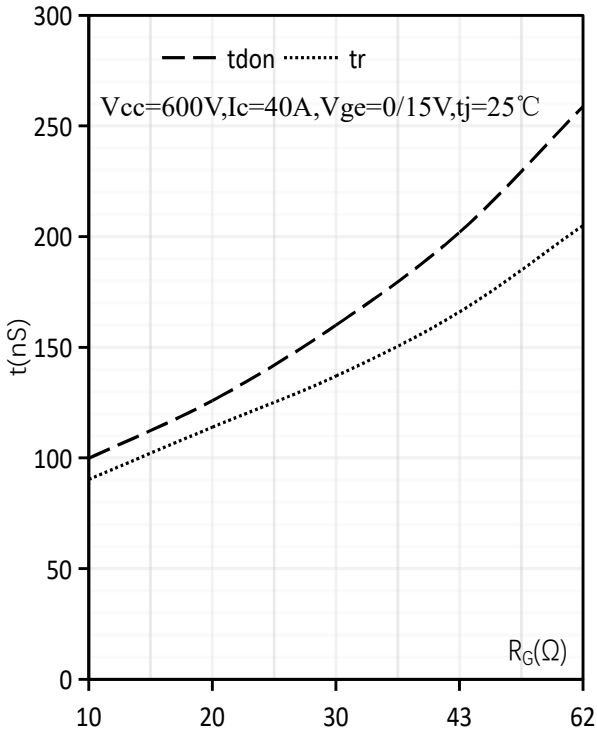

开启时间-门极电阻特性/Typical switching times as a function of R_G

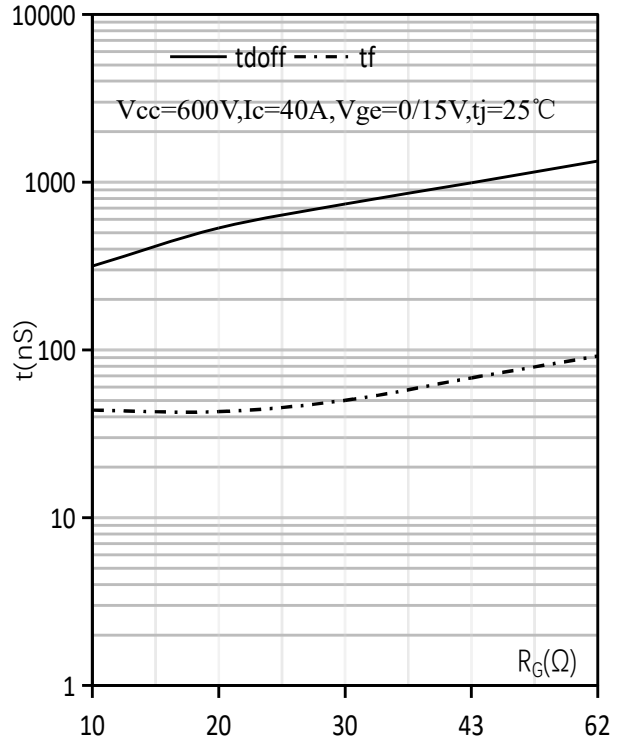

关闭时间-门极电阻特性/Typical switching times as a function of R_G

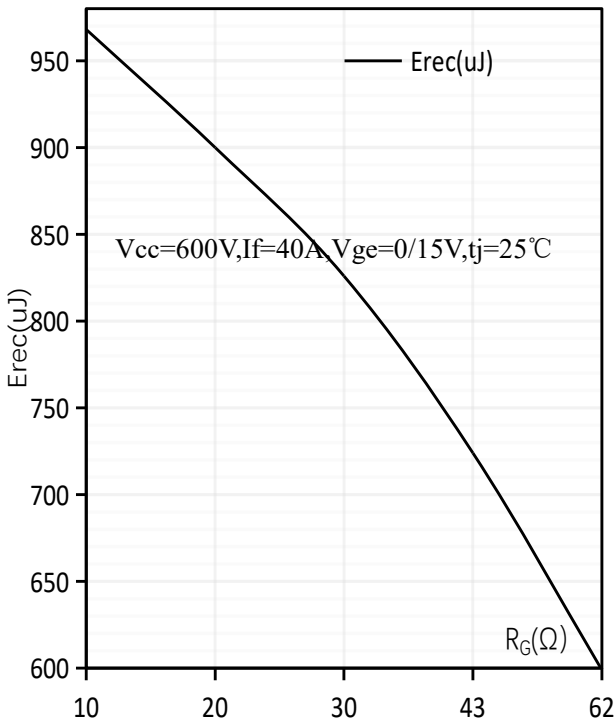

反向恢复损耗-门极电阻特性/Typical E_{REC} as a function of R_G

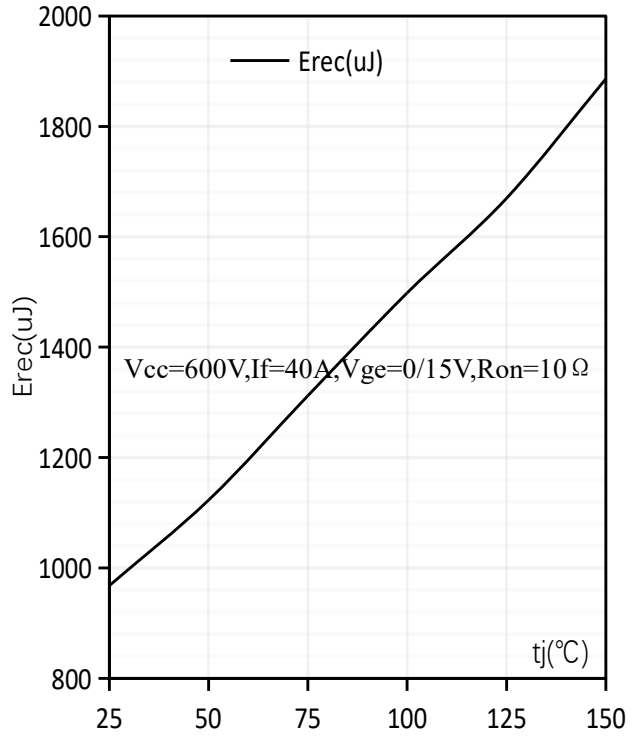

反向恢复损耗-温度特性/Typical E_{REC} as a function of t_j

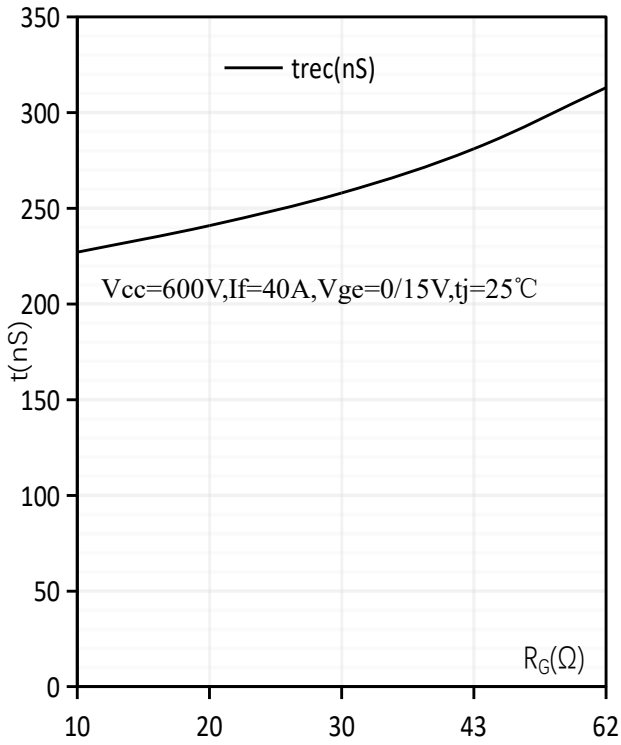

反向恢复时间-门极电阻特性/Typical t_{rec} as a function of R_G

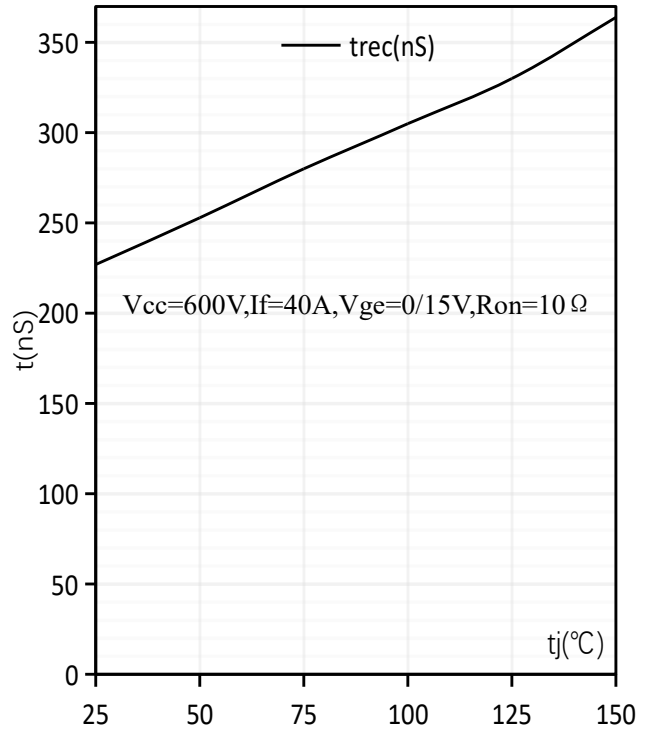

反向恢复时间-温度特性/Typical t_{rec} as a function of t_j

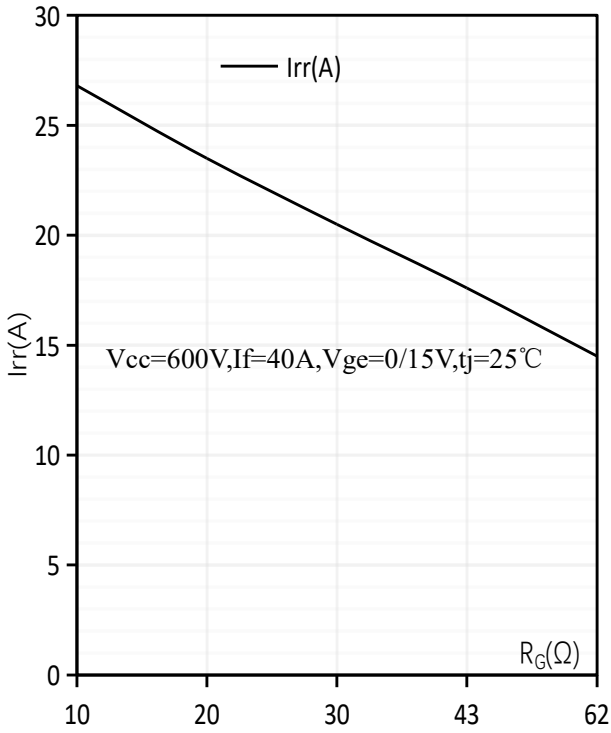

反向恢复电流峰值-门极电阻特性/Typical I_{rr} as a function of R_G

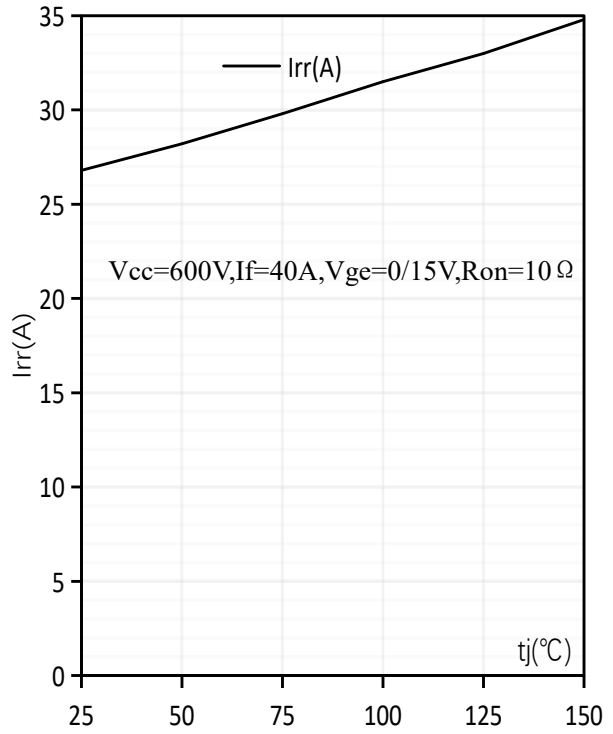

反向恢复电流峰值-温度特性/Typical I_{rr} as a function of t_j

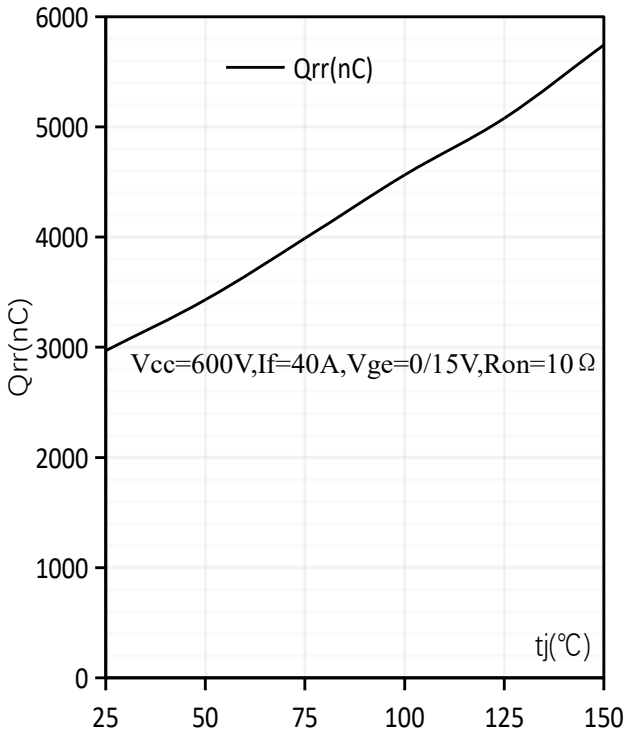

反向恢复电量-温度特性/Typical Q_{rr} as a function of t_j

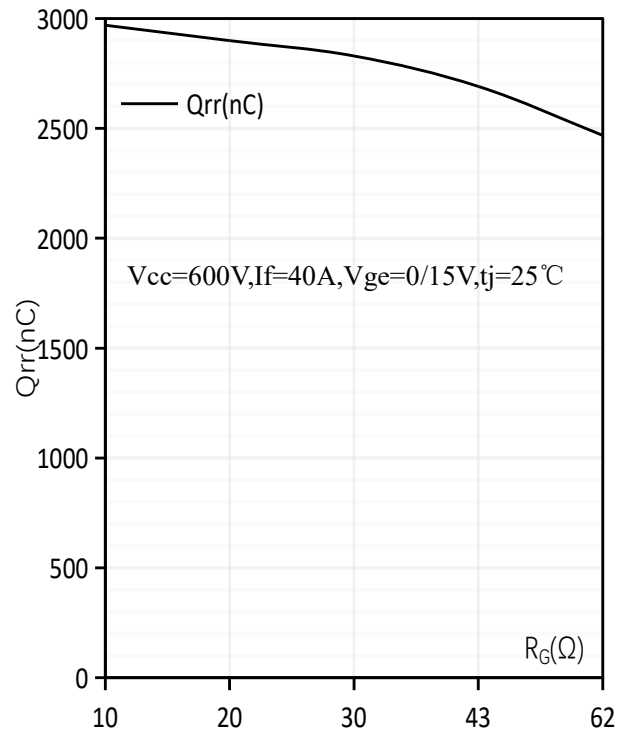

反向恢复电量-门极电阻特性/Typical Q_{rr} as a function of R_G

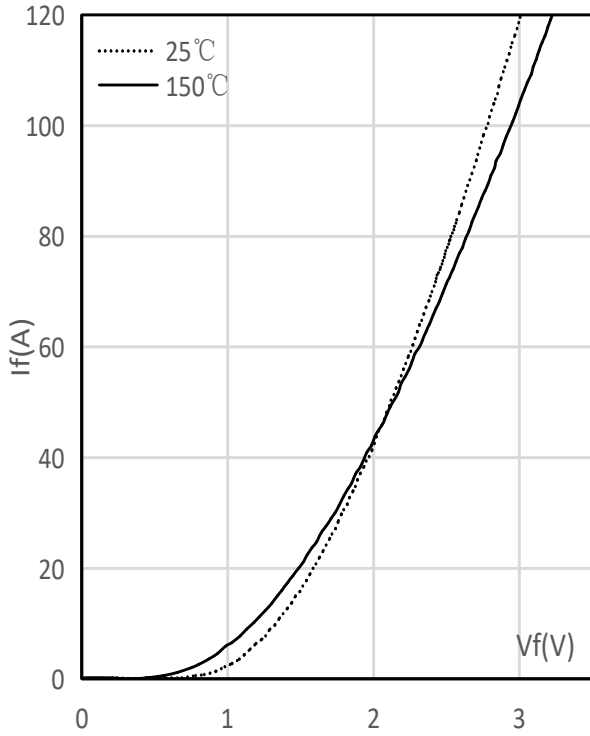

二极管压降/Typical I_F as a function of V_F

● **丝印信息/Marking Information**

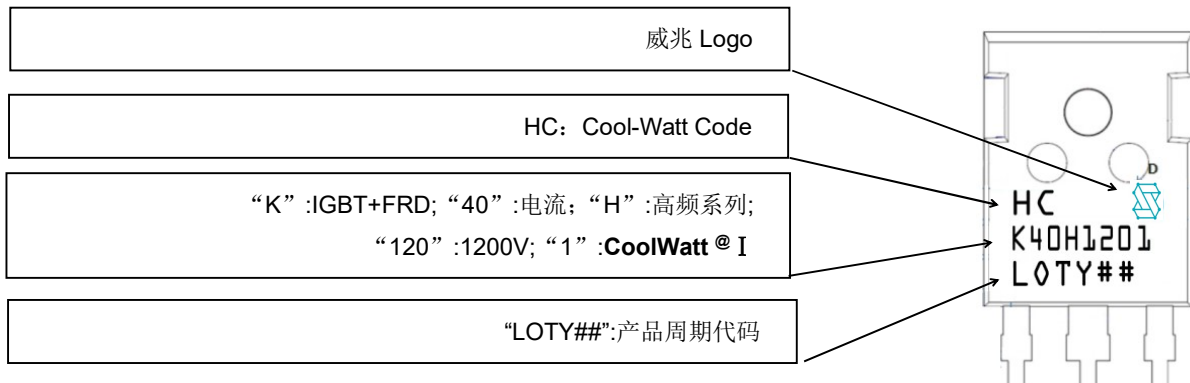

● To-247 尺寸数据/TO-247 Package Outline Data

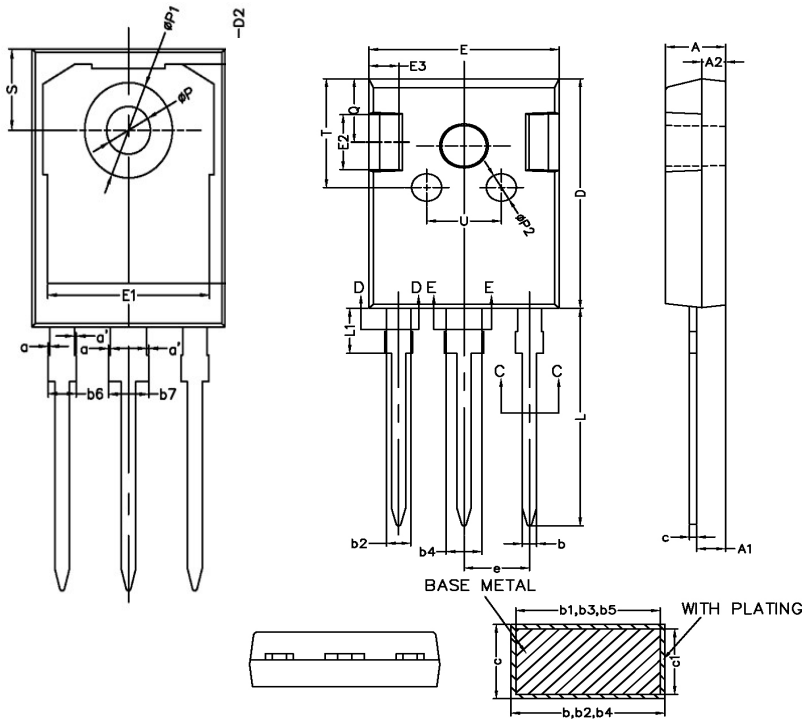

SYMBOL	MIN	NOM	MAX
A	4.90	5.00	5.10
A1	2.31	2.41	2.51
A2	1.90	2.00	2.10
a	0	—	0.15
a'	0	—	0.15
b	1.16	—	1.26
b1	1.15	1.2	1.22
b2	1.96	—	2.06
b3	1.95	2.00	2.02
b4	2.96	—	3.06
b5	2.95	3.00	3.02
b6	—	—	2.25
b7	—	—	3.25
c	0.59	—	0.66
c1	0.58	0.60	0.62
D	20.90	21.00	21.10
D1	16.25	16.55	16.85
D2	1.05	1.20	1.35
E	15.70	15.80	15.90
E1	13.10	13.30	13.50
E2	4.90	5.00	5.10
E3	2.40	2.50	2.60
e	5.34	5.44	5.54
L	19.80	19.92	20.10
L1	—	—	4.30
P	3.50	3.60	3.70
P1	—	—	7.40
P2	2.40	2.50	2.60
Q	5.60	—	6.00
S	6.05	6.15	6.25
T	9.80	—	10.20
U	6.00	—	6.40

TO-247 单位:mm/Unit:mm