

Transient Voltage Suppressors (TVS) Data Sheet

Features

- Glass passivated junction
- Low inductance
- Excellent clamping capability
- 6000W peak pulse power capability at 10/1000µs waveform, repetition rate (duty cycle): 0.05%
- Fast response time
- High Temperature soldering guaranteed: 265°C/10 seconds/.375", (9.5mm) lead length, 5lbs (2.3kg) tension
- Plastic package has underwriters laboratory flammability 94V-0
- Meets MSL level 1, per J-STD-020
- AEC-Q101 qualified
- IEC61000-4-2 ESD 30KV Air, 30KV contact compliance



Mechanical Data

- Case: Moulded plastic over glass passivated junction
- Terminal: Plated Axial leads, solderable per MIL-STD-750, Method 2026
- Mounting Position: Any
- Weight: 2.46g

Applications

- I/O interface
- AC/DC power supply
- Low frequency signal transmission line (RS232, RS485, etc.)
- Meets ISO7637-2 surge spec.

Maximum Ratings and Characteristics

Ratings at 25°C ambient temperature unless otherwise specified.

Rating	Symbol	Value	Units
Peak pulse power dissipation at 10/1000µs waveform (Note1, Fig.2)	P _{PPM}	Minimum 6000	Watts
Peak pulse current of at 10/1000µs waveform (Note 1, Fig.3)	I _{PPM}	See Table	Amps
Steady state power dissipation at T _L =75°C (Fig.5)	P _{M(AV)}	8.0	Watts
Peak forward surge current, 8.3ms single half sine-wave superimposed on rated load, (JEDEC Method) (Note2, Fig.6)	I _{FSM}	300	Amps
Operating junction and Storage Temperature Range.	T _J , T _{STG}	-55 to +150	°C
Typical thermal resistance junction to lead	R _{θJL}	8	°C/W
Typical thermal resistance junction to ambient	R _{θJA}	40	°C/W

Notes: 1. Non-repetitive current pulse, per Fig.3 and derated above T_A=25°C per Fig.2.

2. 8.3ms single half sine-wave, or equivalent square wave, duty cycle=4 pulses per minutes maximum.

Dimensions (P600)

Symbol	Millimeters		Inches	
	Min.	Max.	Min.	Max.
L	25.40	-	1.000	-
T	8.60	9.10	0.340	0.360
d	8.60	9.10	0.340	0.360
s	1.19	1.32	0.047	0.052

Electrical Characteristics (T_A=25°C)

Part Number		Breakdown Voltage @I _T		Test Current	Reverse Stand-Off Voltage	Reverse Leakage @ V _{RWM}	Maximum Clamping Voltage @I _{PP}	Peak Pulse Current				
Unidirectional	Bidirectional	V _{BR MIN.} (V)	V _{BR MAX.} (V)	I _T (mA)	V _{RWM} (V)	I _R (µA)	V _C (V)	I _{PP} (A)				
ATS16A	ATS16C	17	20	5	16	1.8	28	214				
ATS20A	ATS20C	21	25	5	20	1.8	33	182				
ATS22A	ATS22C	24.2	26.9	5	22	1.8	35.5	169				
ATS24A	ATS24C	25	30	5	24	1.8	39	154				
ATS26A	ATS26C	28.9	32	5	26	1.8	42.1	142				
ATS28A	ATS28C	31.1	34.5	5	28	1.8	45.4	132				
ATS30A	ATS30C	33	38	5	30	1.8	50	126				
ATS33A	ATS33C	36.7	40.6	5	33	1.8	53	115				
ATS36A	ATS36C	40	44.2	5	36	1.8	58.1	106				
Part Number		Suitable ISO 7637-2 2004 5a test waveform										
Part Number		Maximum Clamping Voltage	Voltage level			Resistance Level						
Unidirectional	Bidirectional	V _C (V)	87V 400mS	174V 350mS	DC(V)	0.5Ω	1Ω	2Ω	3Ω	4Ω	6Ω	8Ω
ATS16A	ATS16C	28	x	--	13.5	--	x	x	x	x	x	x
ATS20A	ATS20C	33	x	--	13.5	--	x	x	x	x	x	x
ATS22A	ATS22C	35.5	x	--	13.5	--	--	x	x	x	x	x
ATS24A	ATS24C	39	x	--	13.5	--	--	x	x	x	x	x
ATS26A	ATS26C	42.1	--	x	27	--	--	--	--	x	x	x
ATS28A	ATS28C	45.4	--	x	27	--	--	--	--	x	x	x
ATS30A	ATS30C	50	--	x	27	--	--	--	--	x	x	x
ATS33A	ATS33C	53	--	x	27	--	--	--	--	-	x	x
ATS36A	ATS36C	58.1	--	x	27	--	--	--	--	-	x	x

Note: 'x' representatives meets this test condition;

Ratings and Characteristic Curves ($T_A=25^\circ\text{C}$ unless otherwise noted)

Figure 1. ISO 7637-2 5a Test pulse

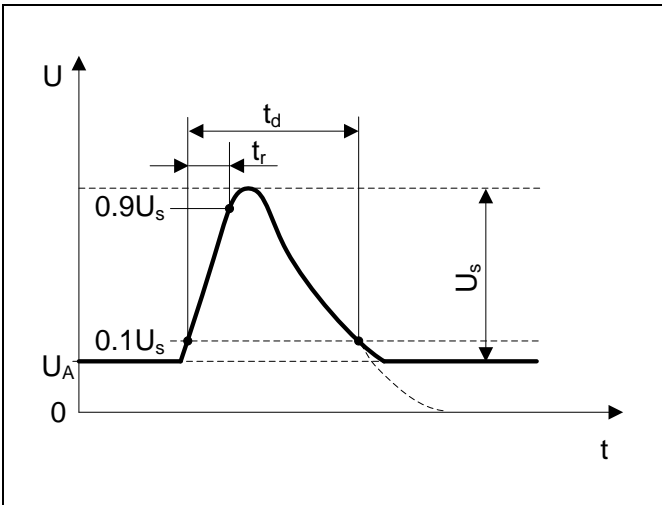

Figure 2. Peak Pulse Power Rating Curve

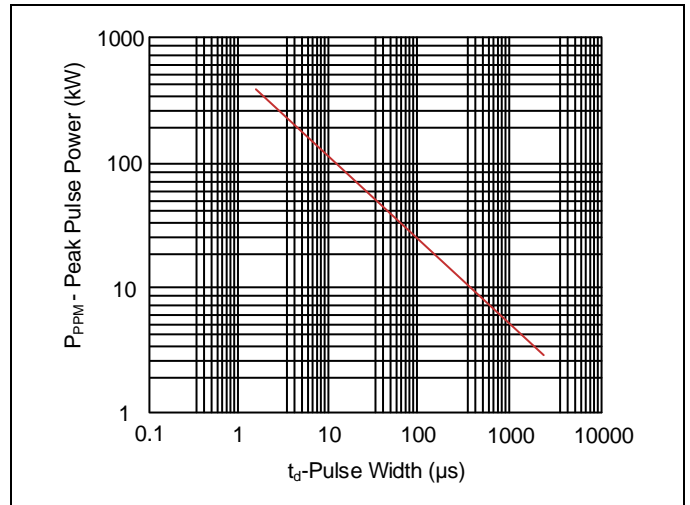

Figure 3. Pulse Waveform

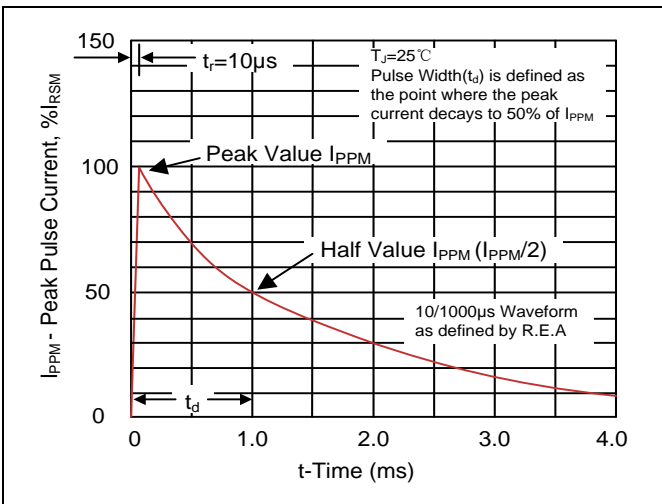

Figure 4. Pulse Derating Curve

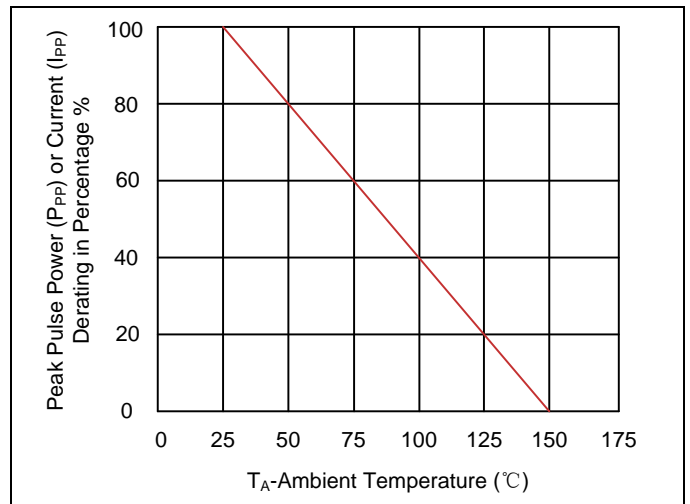

Figure 5. Steady State Power Dissipation Derating Curve

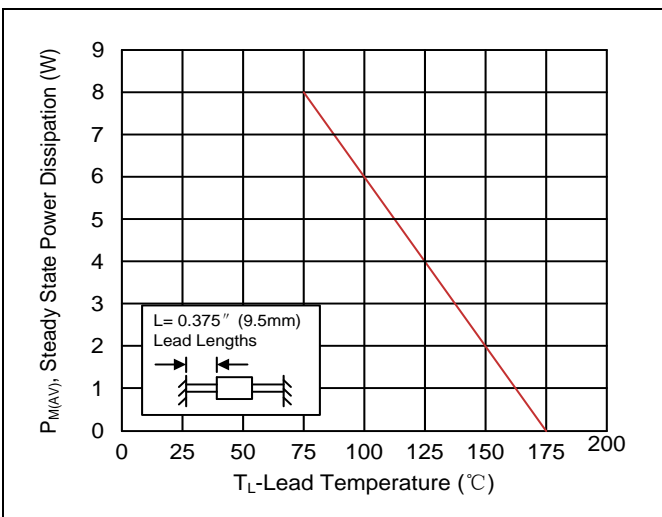
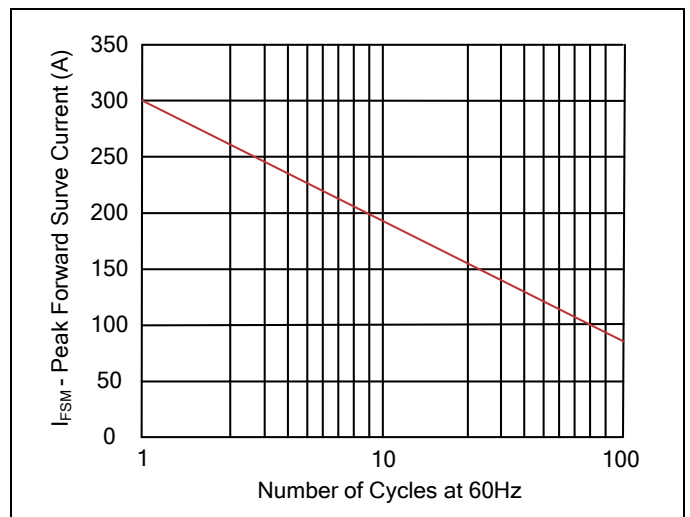
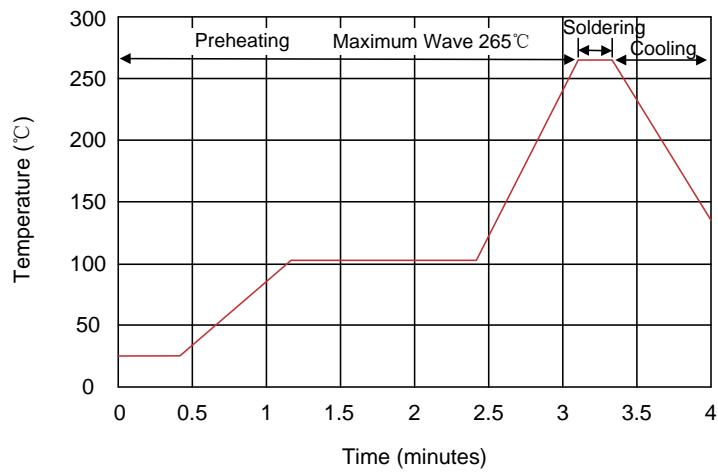

Figure 6. Maximum Non-Repetitive Forward Surge Current Uni-Directional Only



Recommended Soldering Conditions

Wave Soldering



Recommended Conditions

Item	Conditions
Peak Temperature	265°C
Dipping Time	10 seconds
Soldering	1 time

Marking Code

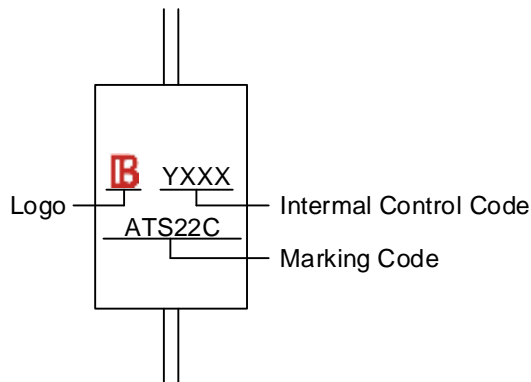

Part Number Code

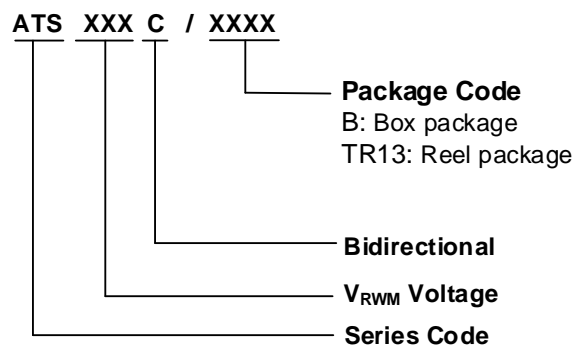

Ordering Code for Different Package

Box package: Add suffix "/B" at the end of the part number, such as ATSXXXC/B

Reel package: Add suffix "/TR13" at the end of the part number, such as ATSXXXC/TR13

Packaging

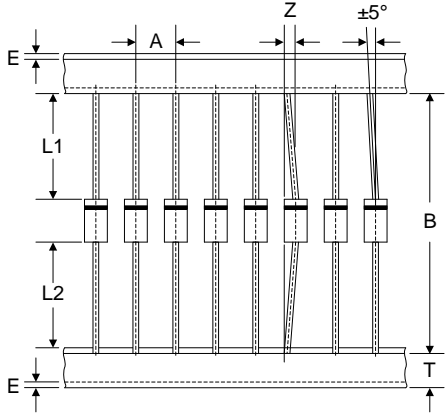
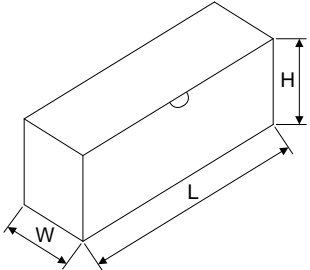
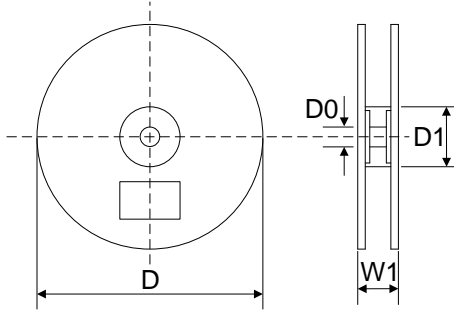
Tape	Symbol	Dimension (mm)
	A	10.0±0.5
	B	53.0±1.0
	Z	1.2Max.
	T	6.0±0.4
	E	0.8Max.
	L1-L2	1.0Max.
	Box	
	L	250.0±5.0
	W	75.0±5.0
	H	114.0±5.0
	Quantity: 300PCS	
Reel		
	D	330.0±3.0
	D0	16.4±2.0
	D1	86.0±2.0
	W1	76.0±3.0
	Quantity: 800PCS	